

D340

DZR Brass Draining Tap



D340

Features & Benefits

- Integrated shroud gives a tamper resistant design
- DZR Brass draining taps are suitable for use on hot and cold water up to 16bar, at temperatures up to 110°C
- Enables system to be drained without removing pipework
- The inlet is a threaded taper male connection to BS EN 10226-2
- The outlet is ribbed for hose connection
- WRAS Approved up to 85°C



GENERAL VALVES

Materials

NO.	NAME	MATERIAL
1	Body	DZR Brass BS EN 12165 CW602N
2	Stem	Brass BS EN 12164 CW614N
3	Bonnet	Brass BS EN 12164 CW614N
4	Disc Holder	Brass BS EN 12164 CW614N
5	Rubber Seat	EP80 (EPDM-WRAS Approved)
6	Stem Packing	EP70 (EPDM-WRAS Approved)
7	Nut (1" Only)	Brass BS EN 12164 CW614N

Dimensions, Coefficients & Weights

SIZE (inch)	A (mm)	B (mm)	C (mm)	D (mm)	E (mm)	F (mm)	WEIGHT (kg)
1/2	53.5	7.0	7.4	9.5	55.9	50.7	0.13
3/4	64.0	7.0	8.5	11.3	68.3	61.7	0.26
1	74.8	7.0	9.5	11.3	82.3	73.7	0.59

Dimensional Drawing

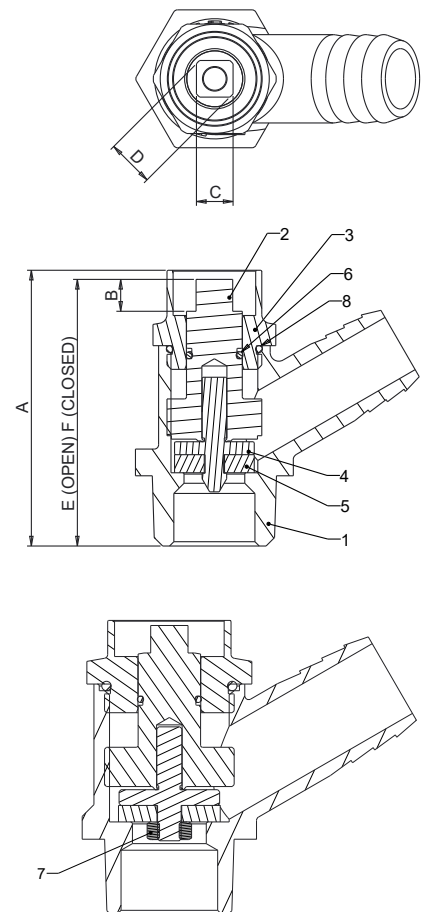
**PRESSURE RATING:** PN16**TEMPERATURE OPERATING RANGE:** 0 to 110°C**UK END CONNECTION:** BS EN 10226-2 Taper**OPERATOR:** Lockshield**SPECIFICATION:** Sizes 1/2" and 3/4" draining taps are designed and manufactured in accordance with BS 2879 type 2.

This valve is excluded from the requirements of the Pressure Equipment Directive 2014/68/EU

Valid as of 290421

Every effort has been made to ensure that the information contained in this publication is accurate at the time of publishing. Crane Ltd assumes no responsibility or liability for typographical errors or omissions or for any misinterpretation of the information within the publication and reserves the right to change without notice.